

VERMONT DIVISION OF EMERGENCY MANAGEMENT & HOMELAND SECURITY



FAMILY EMERGENCY PREPAREDNESS WORKBOOK



45 State Drive • Waterbury, VT 05671-1300
1-800-347-0488 • (802) 241-5556 (Fax)



ARE YOU PREPARED FOR A DISASTER?

Disasters can happen anytime, with or without warning. A disaster can be the result of a man-made incident such as a terrorist attack, or natural event like a flood or ice storm. Vermont's history demonstrates that no community is immune to the effects of a disaster, so it is important to take steps now to prepare.

This workbook highlights some of the steps you can take now to prepare yourself, your family, your business, and your community. Determine what hazards may affect you and take steps to mitigate their impact. Address any special concerns or circumstances you have with local emergency managers. Ready yourself and your family by creating a disaster supply kit and disaster plan. Educate yourself by enrolling in disaster preparedness, response, and recovery courses.

During an emergency, safety and well-being are top priorities. To best prepare for a disaster it is important to create a disaster supply kit which has at least three days worth of fresh water, non-perishable food, medications, and batteries for things like flashlights. It is also important that you have a battery powered radio so you can stay informed. Follow the suggestions in this workbook and visit www.Ready.gov for help in building your kit.

Emergency planning is a key part of being prepared. Create an emergency plan for your family or business. If a disaster occurs, how will you contact each other? What will you do about your pets? Which documents are important and should be protected from flood waters? These are some of the questions that your plan should answer.

When making your emergency plan, assess your home or business for potential hazards. Your municipality's Emergency Management Director can assist you. It is important to take steps now to reduce the impact hazards can have on you. Among the different hazards faced by Vermonters flooding ranks among the most likely and most costly. The Federal Emergency Management Agency (FEMA) manages the National Flood Insurance Program. For more information go to www.floodsmart.gov.

This workbook is intended to help get you started with disaster preparedness. For more information contact your local Emergency Management Director or the VT Division of Emergency Management and Homeland Security.

Division of Emergency Management and Homeland Security
45 State Drive Waterbury, VT 05671-1300
1-800-347-0488
<http://dps.vermont.gov>

The information and photographs in this publication are provided by a number of sources, including the Vermont Division of Emergency Management and Homeland Security, Vermont Agency of Transportation, Vermont State Police and the American Red Cross.

This document is provided free of charge. Additional copies may be requested from DEMHS.

DEMHS does not endorse any single commercial product or service.

Comments about this workbook should be forwarded to: Vermont Division of Emergency Management and Homeland Security
45 State Drive
Waterbury VT 05671-1300

DISASTER PREPAREDNESS CHECKLIST

- Identify a friend or relative in a different state who can coordinate communications in case your family is separated.
- Talk with officials about school disaster plans.
- Prepare a disaster supply kit with emergency supplies (including but not limited to):
 - Flashlight with extra batteries;
 - Whistle for emergency signaling;
 - Portable, battery-operated radio with extra batteries;
 - First Aid Kit and manual;
 - Emergency food and water supplies for three days;
 - Non-electric can opener;
 - Essential medicines for at least seven days;
 - Cash and credit cards;
 - Other supplies necessary for life (non-perishable food, water, etc.).
- Make a list of important items and stores where they can be purchased:
 - Special equipment and supplies, e.g., hearing aid batteries;
 - Current prescription names and dosages;
 - Names, addresses, and telephone numbers of doctors and pharmacists;
 - Detailed information about your medication regimen and medical history.
- Ensure that all family members wear appropriate medical-alert tags.
- Know the location of shelters, evacuation points and routes in your community.
- Do a hazard assessment of your home and mitigate identified hazards.
- Know the location of and how to shut off your home's utilities.
- Talk with your children about what they should do during an emergency.
- Keep important phone numbers listed by the telephone and teach children how and when to call 9-1-1.
- Purchase a NOAA Weather Radio with a tone alert feature to stay informed about severe weather and other important information.
- Consult with your insurance agent about your insurance coverage, as most policies do not cover earthquake or flood damage. Protect valuable property and equipment with special riders and consider obtaining business continuity insurance.
- Determine how you will protect your pets or animals in the event of a disaster – some shelters do not allow pets (working service animals are permitted).
- Check that all smoke and carbon monoxide detectors are working. Every six months change the smoke and carbon monoxide detector batteries and the perishable supplies in your disaster kit.
- Speak with neighbors about their emergency plans, and how you can help each other during a crisis.
- Enroll in a CPR, first aid or disaster preparedness course.

BUILD A FAMILY DISASTER KIT

A disaster kit should contain all of the items that you would need for three days. It should be stored in a place that has easy access. All family members should know where the kit is located and the contents should be checked or replaced every six months. It is important that the kit be easy to move so that you can take it with you if you evacuate.



- ⇒ Include in the kit important documents such as medical and financial records, maps, emergency contact lists, etc.
- ⇒ If you have children, include a favorite stuffed animal, blanket, books, games or toys.
- ⇒ Store at least one gallon of water per person per day. Store the water in clean plastic containers. Label and date each container, replacing the stored water every six months.
- ⇒ Pack blankets, a first aid kit, prescription medications, a non-electric can opener, a pack of playing cards, tools, medications, clothing, hygiene supplies, a battery-powered radio, and flashlight with extra batteries.
- ⇒ Pack an envelope of cash.
- ⇒ Store non-perishable foods that do not require refrigeration or cooking and need little or no water. Store the food in a plastic or metal container to protect from pests. Label and date each container, replacing the food every six months. Include a can of solid fuel and matches to heat the food.

Examples of food items include:

- ready-to-eat meats;
- dried cereal, fruits or vegetables;
- canned or dried soups and juices;
- peanut butter and non-perishable jelly;
- food for infants or people on special diets;
- salt, pepper, spices, sugar;
- candy or cookies;
- instant coffee or tea;
- crackers or trail mix;
- food for your pets.



- Keep canned foods in a dry place where the temperature is cool.
- Throw out any canned good that becomes swollen, dented, or corroded.
- Re-think your needs every year and update your kit as your family needs change.
- Keep items in airtight plastic bags and put your entire disaster supply kit in one or two easy-to-carry containers.

Emergency Protective Actions

During an emergency, officials may recommend that you and your family take an emergency protective action. This could include evacuating your home or business, sheltering-in-place, or some other action. Through the Emergency Alert System (EAS), which utilizes commercial radio, television, cell phones, internet, and cable systems, emergency management officials broadcast instructions and information about the emergency. The NOAA weather alert radio, which receives weather information broadcast by the National Weather Service, can also receive EAS messages. These radios are available for purchase at your local hardware or electronics store.

How to Evacuate

When conditions threaten life or safety, public safety officials may order an evacuation. If you need to evacuate your home or business follow these guidelines:

- ⇒ Gather all persons in the house and leave together, taking your disaster supply kit with you.
- ⇒ DO NOT try to pick up children at their schools. They will be taken to a designated reception center or shelter outside the area where you may pick them up.
- ⇒ Household members outside the area may be advised not to return during an evacuation. They will be directed to the reception center or shelter where they can join you.
- ⇒ Listen to an emergency alert radio or television station for information and instructions. Listen carefully to the Emergency Alert System for information about evacuation routes and follow those instructions. Local officials may alter the routes to expedite evacuations. Unless it is an emergency, DO NOT call your local fire or police department for information. Emergency workers will need their telephone lines available for emergency use.
- ⇒ Wear protective clothing and sturdy shoes.
- ⇒ Close and lock windows and doors.
- ⇒ Check with neighbors to see if they need assistance or transportation.
- ⇒ If you have livestock, unless otherwise instructed, shelter them with a three day supply of feed and water.
- ⇒ Obey all traffic control officials along your route.

If you have time...

- ⇒ Turn off lights, unnecessary appliances, water, and gas connections.
- ⇒ Make arrangements for pets as they may not be allowed in shelters.
- ⇒ Notify a friend or family member, who is out of the area, where you are going and when you plan to leave.

How to Shelter-In-Place

When conditions threaten life or safety, public safety officials may order you to shelter-in-place. This means you should immediately go indoors. If a shelter-in-place message is given for your community, you should do the following:

- ⇒ Go indoors and close all doors and windows. Turn off all window fans, air conditioners, clothes dryers, kitchen and bath exhaust fans, and other sources of outside air.
- ⇒ Keep pets indoors. If you have livestock, shelter them too. Use stored feed and water from a covered source.
- ⇒ If you are traveling in a motor vehicle, close the windows and air vents and turn off the heater or air conditioners.
- ⇒ If sheltering-in-place is ordered during school hours, children will be sheltered in the school building and cared for by school personnel.

WINTER PREPAREDNESS

In Vermont, winters can bring heavy snowfall and extremely cold temperatures. Snow can block roads and cause power lines to fall. The cold temperatures can be dangerous if outdoor travelers are not dressed properly. Hypothermia is a medical emergency which occurs when a person is in cold temperatures for a long time. The elderly and very young are particularly susceptible to hypothermia. It is important to listen to weather reports and heed winter weather warnings. Dressing appropriately for the weather is often the best protection against hypothermia.

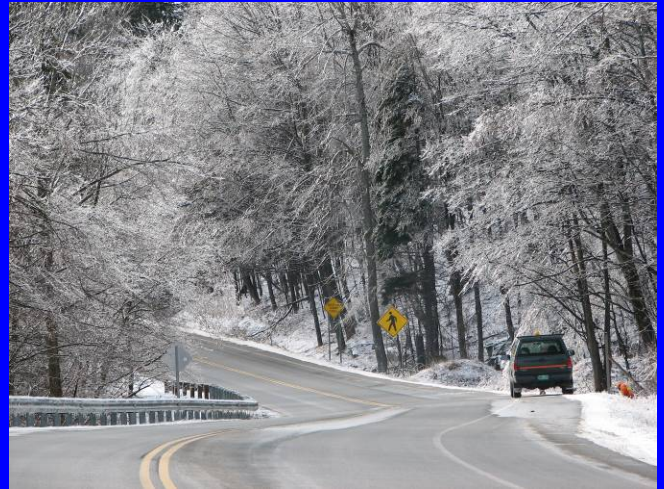

Vehicle safety precautions are also vital during the winter. Vehicles should have cold weather gear in case of a breakdown. If stranded during a winter storm you should remain in your vehicle, stay awake, and take steps to stay warm. To prevent carbon monoxide poisoning, ensure your exhaust pipe is not obstructed. During extreme weather, Vermont State Police at times adjust patrol schedules to provide late night aid for motorists on the interstate.

Winter Weather Terms

Freezing rain:	Rain that freezes when it hits the ground, creating a coating of ice on roads and walkways
Sleet:	Rain that turns to ice pellets before reaching the ground causing roads to freeze and become slippery
Winter Weather Advisory:	Cold temperatures, ice and snow are expected
Winter Storm Watch:	Severe weather such as heavy snow or ice is possible in the next day or two
Frost/Freeze Warning:	Below freezing temperatures are expected
Winter Storm Warning:	Severe winter conditions have begun or will begin very soon
Blizzard Warning:	Heavy snow and strong winds will produce a blinding snow, near zero visibility, deep drifts and life-threatening wind chill

Why should you be prepared?

So you can be ready to take care of you and your family in a timely manner.



Homeland
Security

Ready 

For additional information on emergency preparedness you can visit

<http://www.ready.gov>

FLOODS

As we saw in the historic disasters of 2011, flooding can and does happen year round in Vermont. Quick thaws and ice jams in the winter and spring; and heavy rains in the summer and fall cause rivers and streams to swell and spill their banks. That's why it's critical to be prepared for flooding all year.

- Know the terms used to describe flooding:
 - Flood Watch – Flooding is possible. Watches are issued by the National Weather Service (NWS) 12 to 36 hours in advance of a possible event.
 - Flash Flood Watch – Flash Flooding is possible. Be prepared to move to higher ground. A Flash Flood could occur without warning.
 - Flood Warning – Flooding is occurring, or will occur soon. If advised to evacuate, do so immediately.
 - Flash Flood Warning – A flash flood is occurring. Seek higher ground immediately and stay away from streams and creeks.
- If you ever encounter flood waters NEVER attempt to walk or drive through them.
- Monitor Media reports.
- Ask local officials whether your property is in a flood-prone or high-risk area. Flood plain maps are available at most town offices or city halls.
- Listen to local and state Public Safety officials and respond to their directives in a prompt manner.
- Know your best flood evacuation routes, potential public shelters, and where to find high ground. In a flash flood, you may need to seek high ground on foot quickly.
- Ensure your home is ready. Where possible, minimize damage from basement flooding by elevating utilities and materials that could be damaged by limited basement flooding.
- Anchor fuel tanks to ensure that they do not wash away, creating a safety and environmental hazard inside or outside the home.
- Be prepared to turn off electrical power when there is standing water, fallen power lines, or before you evacuate. Know how to safely turn off gas and water supplies before you evacuate.
- Contact your insurance agent or local government to discuss flood insurance coverage. Flood losses are not covered under regular homeowner's insurance policies. The Federal Emergency Management Agency (FEMA) administers the National Flood Insurance Plan (NFIP) through the Federal Insurance Administration (FIA). The NFIP makes flood insurance available in communities that adopt and enforce ordinances to reduce flood damage.

For more information visit:

<http://www.floodsafety.noaa.gov/> or <http://www.ready.gov>

Pandemic Influenza

It's not your 3 day flood. . .

You can and should prepare for an influenza pandemic now. You should know both the magnitude of what can happen during a pandemic outbreak and what actions you can take to help lessen the impact of an influenza pandemic on you and your family. This checklist will help you gather the information and resources you may need in case of a flu pandemic.

To plan for a pandemic:

- Store a two week supply of water and non-perishable food such as rice or canned goods. During a pandemic, if you cannot get to a store, or if stores are out of supplies, it will be important for you to have extra supplies on hand. This can be useful in other types of emergencies, such as power outages and disasters.
- Have any nonprescription drugs and other health supplies on hand, including pain relievers, stomach remedies, cough and cold medicines, fluids with electrolytes, and vitamins.
- Talk with family members and loved ones about how they would be cared for if they got sick, or what will be needed to care for them in your home.
- Volunteer with local groups to prepare and assist with emergency response.
- Get involved in your community as it works to prepare for an influenza pandemic.

To limit the spread of germs and prevent infection:

- Teach your children to wash hands frequently with soap and water, and model the correct behavior.
- Teach your children to cover coughs and sneezes with tissues, and be sure to model that behavior.
- Teach your children to stay away from others as much as possible if they are sick. Stay home from work and school if sick.

(information from www.pandemicflu.gov)

For more information on Pandemic Influenza please visit the Vermont Department of Health at:

<http://healthvermont.gov>

Prevent Wildfires

Dry and breezy conditions often bring with them high risks of wildfires in Vermont. In windy conditions fires that do occur can spread rapidly and become unmanageable. Local fire departments throughout the state respond to numerous wildfires throughout the prime burning seasons each year.

April and May are the high season for conditions that exacerbate wildfire risks – and with increased potential for wildfires comes a heightened need for everyone to take certain precautions. In general, debris burning is the leading cause of wild land fires in Vermont. These fires cause property damage; lost natural resources; and like all fires, can result in a loss of life. Most people never intend to start a wildfire and can avoid this by choosing a day to burn when fire danger is low. Persistent dry and windy weather makes grass, brush, and leaves susceptible to uncontrolled fires, but common sense and caution can prevent wildfires.

Vermonters can help prevent and prepare for wildfire:

- By state law, a “Permit to Kindle Fire” (an open burning permit) **MUST** be obtained from the Town Forest Fire Warden and is **REQUIRED** before you start to burn any natural wood or vegetation outdoors.
- Avoid burning on dry, windy days or when Fire Weather Watches or Red Flag Warnings are issued by the National Weather Service.
- If you can legally and safely burn: Burn small piles; gradually adding to the fire as it burns down. Large piles of burning debris generate intense heat capable of carrying burning embers up and into other areas.
- Clear all dry grass and weeds from around your burn area, and around your home and out-buildings.
- Always have tools handy while you burn - including water, a hose, a rake and a shovel.
- If burning a large agricultural area, please check with your local fire department for advice about burning it safely.
- **CALL 911** or your local fire department if your burn gets out of control and becomes a wildfire. If you delay calling for help, you may have disastrous results.
- **DO NOT** attempt to suppress a wildfire, if it cannot be done **EASILY** with the tools and water you have on hand.

Additional Information links:

Vermont Agency of Natural Resources - Department of Forests, Parks & Recreation - Forest Fire Control Page: http://www.vtfrpr.org/protection/for_protect_firecont.cfm

Vermont Division of Fire Safety seasonal safety page: http://firesafety.vermont.gov/safety_issues/SEASONAL

National Weather Service Fire Weather Page: <http://www.erh.noaa.gov/btv/html/firewx/>

Vermont 2-1-1

Do you need help finding help? Are you facing difficult times and do not know where to turn? Looking for help with everyday needs? Dialing 2-1-1 is your first step. Vermont 2-1-1 is a simple number to dial for information about health and human service organizations in your community. By dialing 2-1-1, information is much easier to find.

At Vermont 2-1-1, callers will speak with a real person every time. Call Specialists will problem solve and refer callers from throughout Vermont to government programs, community-based organizations, support groups, and other local resources.

Vermont 2-1-1 is:

- A local call from anywhere in Vermont.
- Confidential telephone assistance.
- Available 24 hours a day, 7 days a week.
- Live translation services for 170 languages.
- Access for persons who have special needs.
- Ability to transfer emergency calls to 9-1-1.
- Accurate information about community resources in Vermont.



Vermont 2-1-1 provides all people in Vermont with free access to community resources through information and referral. This access includes personal assistance by telephone and online through a searchable database of services, including the following:

- Child Care Resource and Referral
- Clothing and Thrift Shops
- Crisis Services
- Discrimination Assistance
- Domestic and Sexual Violence Services
- Education - GED Instruction, Computer Classes
- More

Just dial 2-1-1





www.vtalert.gov

Vermonters have a new tool at their disposal to stay informed of pending disasters, traffic information, weather conditions, public health notifications, and countless other alerts that could affect themselves or their loved ones.

Vermont Alert (www.vtalert.gov) is a free service for users. It allows the public to sign up and receive notifications through a number of delivery systems, including text, e-mail, telephone, or even a game console. Alerts are localized to areas users chose and are issued state and local responders and other agencies.

Users chose their alert areas, what types of alerts they wish to receive, and which delivery systems they prefer.

Sign up for an account today by visiting www.vtalert.gov

VT Alert Delivery Platforms—

You decide how:

- Email
- Text
- Phone Call
- Page
- Gaming Console
- More ...

VT Alert Notifications—

You decide what:

- Weather
- Amber Alert
- Evacuation
- Road Closures
- Evacuations
- More ...



CERT—Community Emergency Response Team



The Federal Emergency Management Agency began promoting the nationwide Community Emergency Response Team (CERT) concept in 1994. Since then, CERTs have been established in hundreds of communities; including several in Vermont.

CERT training promotes a partnering effort between emergency services and the people they serve. The goal is for emergency personnel to train members of neighborhoods, community organizations, or workplaces in basic response skills. CERT members are then integrated into the emergency response capability for their area.

CERT members can assist by applying the basic response and organizational skills that they learn during training. These skills can help save and sustain lives following a disaster until help arrives.

CERT members maintain and refine their skills by participating in their team's monthly or bi-monthly meetings, community exercises, and preparedness activities. They continue to refine their skills and expand their knowledge at the monthly or bi-monthly training meetings and by attending locally offered relevant training. CERT members also have the opportunity to work with their communities to improve individual and community emergency preparedness.

CERT training will teach participants to: Describe the types of hazards most likely to affect their homes and communities; describe the function of CERT and their roles in response; take steps to prepare themselves and their family for a disaster; identify and reduce potential fire hazards in their homes; work as teams to solve different problems; apply techniques in conducting triage; performing head to toe assessments; sizing-up requirements for potential search and rescue situations; and using safe techniques for debris removal.



The 20 hour CERT Training is designed to cover: Disaster preparedness, fire safety, directing traffic, disaster medical operations—triage and treating life threatening injuries, disaster medical operations—assessment treatment and hygiene, light search and rescue, team organization, disaster psychology, terrorism and CERT, and a final exercise.



Training programs vary; some CERT programs train over a full weekend and others train one night a week for seven to eight weeks.



For more information on the Vermont CERT program please visit:
vem.vermont.gov/programs/cert, call 1-800-347-0488
or email vtcert@state.vt.us

ANIMALS IN DISASTERS

70% of Vermont households own a pet. While community disaster plans try to incorporate the care for animals in their plans, the plans can often only coordinate care — they cannot always provide it. Therefore, the best way for an animal owner to be prepared is to create a specific emergency plan that includes provisions for your animals. More and more emergency shelters now accommodate pets, but not all do, so you should find an out-of-area friend or business that can house your animals in the event you need to evacuate your home. Farm evacuations present unique problems. Appropriate planning is essential. Evacuations are best coordinated with neighbors, friends, livestock associations and horse clubs, and extension educators. Both the destination and the method of transport need to be sorted out well in advance of any disaster. It is important that animals be identified and up to date on vaccines. It is advisable to create a disaster kit for your pet including food, a leash and other important items.

POWER OUTAGES

Vermonters know a thing or two about power outages. The rural landscape and frequency of storms ensures that the lights will go out from time to time. It is important to take some simple steps to stay safe during an outage:

- Have batteries, a flashlight, and a battery powered radio on hand.
- If power is expected to be out for an extended period, seek shelter elsewhere if it is cold outside. Don't wait until it is too late to seek alternative shelter. Call 2-1-1 for shelter information.
- Call your power company to report the outage.
- Elderly residents and those with special needs should contact their power company today to alert the company to those needs in the event of a power outage.
- Check in with elderly residents during power outages from time to time.
- Never touch a downed power line or anything touching a power wire as it could cause electrocution and death. Treat every power line as if it were live.
- Stay warm. If it's cold, keep your head, hands and feet covered. Several layers of light clothing usually work better than a single heavy layer.
- Locate and check all emergency supplies and equipment to ensure that you are prepared. Food will stay frozen in a fully loaded freezer for 36 to 48 hours if the door is kept shut. If the freezer is only half full, the food will keep for about 24 hours. Meat keeps longer than baked goods. Try not to open your freezer or refrigerator when the power is out unless it is necessary.
- Disconnect or shut off appliances that will go on automatically when power is restored. This includes furnaces, air conditioners, electric ranges, water heaters, refrigerators, freezers, and water pumps. Also make sure electric space heaters, washers, dryers, and TV sets are shut off. If a lot of appliances come on at once, they may overload the circuits. Leave one or two lamps switched on so you'll know when the power comes back on. Then you can turn your appliances back on one at a time over a period of 15 minutes or so.
- Don't use an unvented kerosene space heater.
- Don't use a gas range to heat your home.
- If using a generator, make sure it is operated outside. An inadequately vented generator can lead to carbon monoxide poisoning and death. Also, make sure your generator is properly installed; an improperly installed generator can feed back onto power lines, putting power crews at risk of electrocution.



Home Fire Safety Tips

FIRE SAFETY

Fire is a serious public safety concern and our homes are where we are at greatest risk from fire. Each year in Vermont, fire kills an average of 11 people; 1,000 people are treated for fire and burn injuries; and an estimated \$82-million in property is lost.

To protect yourself, it is important to understand the basic characteristics of fire. Fire spreads quickly; there is no time to gather valuables or make a phone call. In just two minutes, a fire can become life-threatening. In five minutes, a residence can be engulfed in flames.

Properly working smoke alarms double your family's chance of surviving a fire. Place smoke alarms on every level of your residence. Place them in accordance with the manufacturer's instructions outside bedrooms on the ceiling or high on the wall (4 to 12 inches from ceiling), at the top of open stairways, or at the bottom of enclosed stairs and near (but not in) the kitchen or bathroom.

Make sure windows are not nailed or painted shut. Make sure security gratings on windows have a fire safety opening feature so they can be easily opened from the inside.

Consider escape ladders if your residence has more than one level, and ensure that burglar bars and other anti-theft mechanisms that block outside window entry are easily opened from the inside.

For further assistance, ask your local fire department to inspect your residence.

SMOKE DETECTORS

Fire and public safety officials urge citizens to remember to change their smoke and carbon monoxide detector batteries when they change their clocks in the spring and fall. More than 90% of American homes have smoke detectors, but an estimated one-third are either not working or missing batteries. Residential fires represent about 25% of all fires, and unattended cooking or human error are the leading causes. Careless smoking, however, is the leading cause of fire deaths. It is important that smoke detectors be installed in proper locations and be checked at least once a month. Many local fire departments offer free smoke and carbon monoxide detectors or fire prevention programs.

Important tips to avoid fires during the winter heating season:

- Install ionization *and* photoelectric smoke alarms and carbon monoxide alarms on every level of the home.
- Keep 3' / 36" / 1 meter between heating equipment and anything that can burn - or in accordance with manufacturer's instructions.
- Never leave portable space heaters and candles unattended - turn off heaters before going to bed.
- Clean chimneys and vent pipes annually – put ashes in a metal container.
- Unvented heaters should have a carbon monoxide alarm in the same room.
- Never use lighter fluid, kerosene, diesel fuel, or gasoline to start a fire.
- Store gasoline and heating fuels in proper containers outside the home.
- Always use the proper grade and type of fuel for heating equipment.
- Plan and practice escape plans several times a year.
- Install heating equipment in accordance with codes and manufacturer's instructions. It's best to have a professional install the equipment.

CARBON MONOXIDE POISONING

Carbon monoxide (CO) poisoning is a genuine concern every winter. Simply put, CO poisoning can kill you, and improperly heating your house is often the cause.

The initial symptoms of CO poisoning are similar to flu, but without the fever and may include headache, fatigue, shortness of breath, nausea, and dizziness. If you suspect that you are experiencing CO poisoning, get fresh air immediately. Leave the home immediately and call your local fire department for assistance from a safe location.

To avoid CO poisoning take these simple steps:

- Get carbon monoxide detectors for every level of your home as a means of detection.
- Make sure all heating vents are free of snow and other obstructions; if they are covered CO will double back into your home.
- Never run a generator indoors; run it outside or in a well ventilated area.
- Make sure heaters and wood stoves are properly installed by a professional.

GENERATOR SAFETY

When using a generator, it is important to follow these safety tips:

- Follow the manufacturer's instructions when installing and using a generator. An improperly installed generator can feed back onto power lines creating a hazard for utility workers.
- Never use a generator indoors – including inside a garage.
- Operate your generator outdoors or with adequate ventilation.
- Let the generator cool down before refueling.
- Store gasoline and other flammable liquids away from generator and outside of living areas.
- Install carbon monoxide detectors in your home to ensure fumes from the generator are not entering living areas.
- Plug individual appliances into the generator using only heavy-duty, outdoor rated cords with wire gauge adequate for the appliance load.
- Turn off all equipment powered by generator before turning off generator.
- Keep children away from portable generators at all times; many parts are hot and could result in burns.

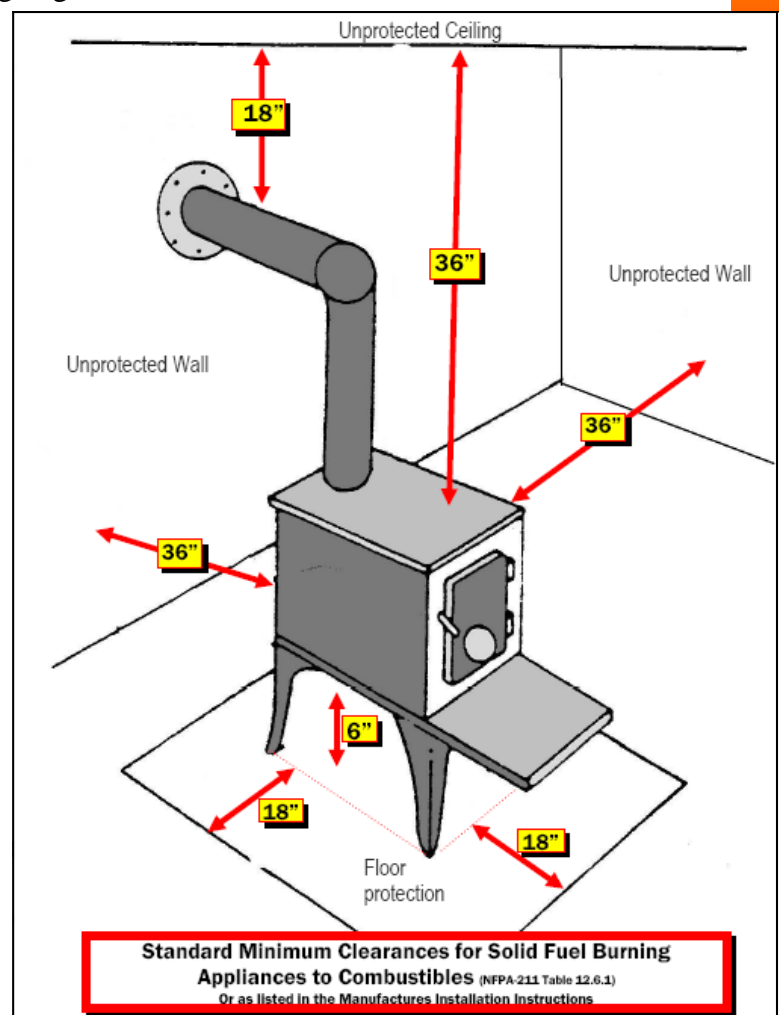

Safe Winter Driving

Drive according to road conditions:

- Check weather and road conditions before you leave.
- Slow Down: Driving too fast on wintry roads is the leading cause of crashes.
- Travel at a safe distance of at least 3 car lengths, leaving plenty of room to stop.
- Clear all snow and ice from the vehicle prior to travel.
- Be aware of black ice on what appears to be bare pavement.
- If your car starts to skid, turn in the direction of the skid. It may seem counterintuitive at first but turning into the skid is your best chance to regain some traction. If you have anti-lock brakes, apply firm and continuous pressure. If you do not have anti-lock brakes, mimic that effect by pumping the brakes.
- If your car doesn't make it to your destination, pull as far off the road as possible to minimize any further traffic hazards, and stay in the car if it is safe to do so. Even a short walk in winter storm conditions can be dangerous.
- If you become stuck in deep snow, do not let your engine idle if your exhaust pipe is buried. Idling with a buried exhaust pipe could lead to carbon monoxide poisoning.
- Carry a cell phone and use 911 in case of an emergency, but do not become over dependent on a cell phone.

Properly Prepare Your Vehicle for Winter Driving:

- Winter tires.
- Wipers and washer fluid.
- Heaters and defrosters.
- Properly adjusted brakes.
- Ensure battery and charging system operate properly.
- Carry tire chains for large trucks.

Be prepared - pack a winter car kit:

- Booster cables.
- Two or more blankets.
- Snow shovel and scraper.
- Flashlight and extra batteries.
- Extra clothing: cap, mittens, parka and overshoes or boots in case you have to walk for help.
- High calorie, non-perishable food like candy and canned nuts.
- Sand or strips of carpet for traction.
- Extra windshield washer fluid and antifreeze.
- Flares or reflectors.



The 511 Travel Information System – for road conditions and weather forecasts, just dial 511 or visit www.511vt.com.

Disaster Preparedness for Vulnerable Populations

Plan and Prepare for an Emergency

Simply put, preparedness is all about **PLANNING!** Emergency preparedness is knowing what to do and being ready to do it promptly and effectively in the event of an emergency. Being prepared means that you have a plan of action—you know what to do before the emergency occurs. To do this, you must know what hazards you face, what resources are available to you, and how to utilize them.

In some cases, such as a flood or hurricane, you may have an early warning, which will give you several hours to act. However, sometimes you will have no prior warning of an emergency, such as with earthquakes, terrorist attacks or major fires.

Use the Disaster Preparedness Checklist on page 2 to make a Disaster Supply Kit. Keep a disaster kit in your home and in each car. A disaster kit for your home should include water, food, first aid supplies, clothing, extra medication, tools, emergency supplies, and any other special items that you would need. Store the items that you would need in the event of an evacuation in an easy-to-carry container.

It is important that local emergency officials know about your special needs **BEFORE** an emergency. This way, your needs can be planned for, and resources allocated, before the emergency begins.



**Notify First
Responders of Special
Needs Before The
Emergency**

What about my Special Medical Needs?

Before a disaster, identify and contact your “support team”. These are people who agree to check in on you and help you during an emergency. These people could include your home aide, a neighbor you know well, a good friend, or a family member who lives with or near you. It is important you have at least two people on your “team” in case one is not reachable. Talk to these people about your emergency plans and needs. You should also make an emergency contact list. This list should include your support team, family members, doctor, pharmacy, and local emergency responders.

Disaster Preparedness Checklist

- Create a self-help network of relatives and friends to assist you in an emergency.
- Contact local first responders so plans can be created to assist you in an emergency.
- Wear appropriate Medical Alert tags and keep a current list of medications and dosages.
- Be ready to give brief, clear, and specific instructions to emergency personnel on how to assist you with devices like wheelchairs.
- Prepare for the requirements (food, water, etc) of your pet or working service animal.
- If you do not drive, talk with your network and local authorities about how to evacuate.
- Ensure a source of backup power for medical support equipment.

Special Alerting Devices

Emergency information is disseminated to the public through the Emergency Alert System (EAS). NOAA Weather Alert Radios, which are activated by the EAS system, have attachments for the deaf and blind communities. Such devices have either a visual signaler or vibrator which are activated by the weather alert radio. These devices are commercially available from many companies.

How can people with special needs get assistance?

Community based emergency management is the best means by which you can receive assistance during an emergency. This means that you **MUST** notify first responders of your needs, preferably before the disaster, by contacting your Local Emergency Management Director or fire chief. Call 2-1-1 if you need further assistance.

ALL INFORMATION WILL BE KEPT CONFIDENTIAL.

Evacuation

During certain disasters it may become necessary for you to evacuate your home. To accomplish this safely and quickly it is important to identify escape routes and modes of transportation beforehand. If you are able to drive, do so. If you do not drive you should contact family, friends and neighbors ahead of time to arrange for possible transport during an evacuation. Your local first responders can also help you with your planning. Prepare a disaster kit that includes extra medication and other necessary items to take with you.

Family Communications Plan

FIRE POLICE MEDICAL Dial 9-1-1

Alternate Local Emergency Number (802) _____ - _____

Your local emergency number is important to know should the 911 system ever fail. It is also important that all family members know what to do in the event of an emergency. Fill out this plan together and review it often. If you have children, discuss emergency and evacuation procedures with school officials.

Home Address: _____

Home Telephone: (____) _____ - _____

Mom's Phone Numbers: work (____) _____ - _____ cell (____) _____ - _____

Dad's Phone Numbers: work (____) _____ - _____ cell (____) _____ - _____

Trusted Neighbor: _____ (____) _____ - _____

Out-of-State Relative: _____ (____) _____ - _____

Contact this individual if your family is separated during an emergency.

Location of Nearest Emergency Shelter: _____

Important Telephone Numbers

New England Poison Control Hotline 1-800-222-1222

Vermont State Police Headquarters 1-800-862-5402

American Red Cross

(Burlington) 1-800-660-9130

(Rutland) 1-802-773-9159

(Brattleboro) 1-802-254-2377

National Weather Service

(Burlington) (802) 862-2475

(Albany) 1-800-239-2123

VTrans Road Conditions Hotline 5-1-1

FEMA Flood Insurance Information 1-800-964-1784

Vermont 2-1-1 2-1-1

(Community Information and Referral)

Home Fire Safety Map

As a family, draw a map of your home and surrounding property. Identify smoke detectors, fire extinguishers, and the exits family members should use to escape from a fire. Mark a safe location where your family will meet after evacuating from a fire (e.g. by the large oak tree).

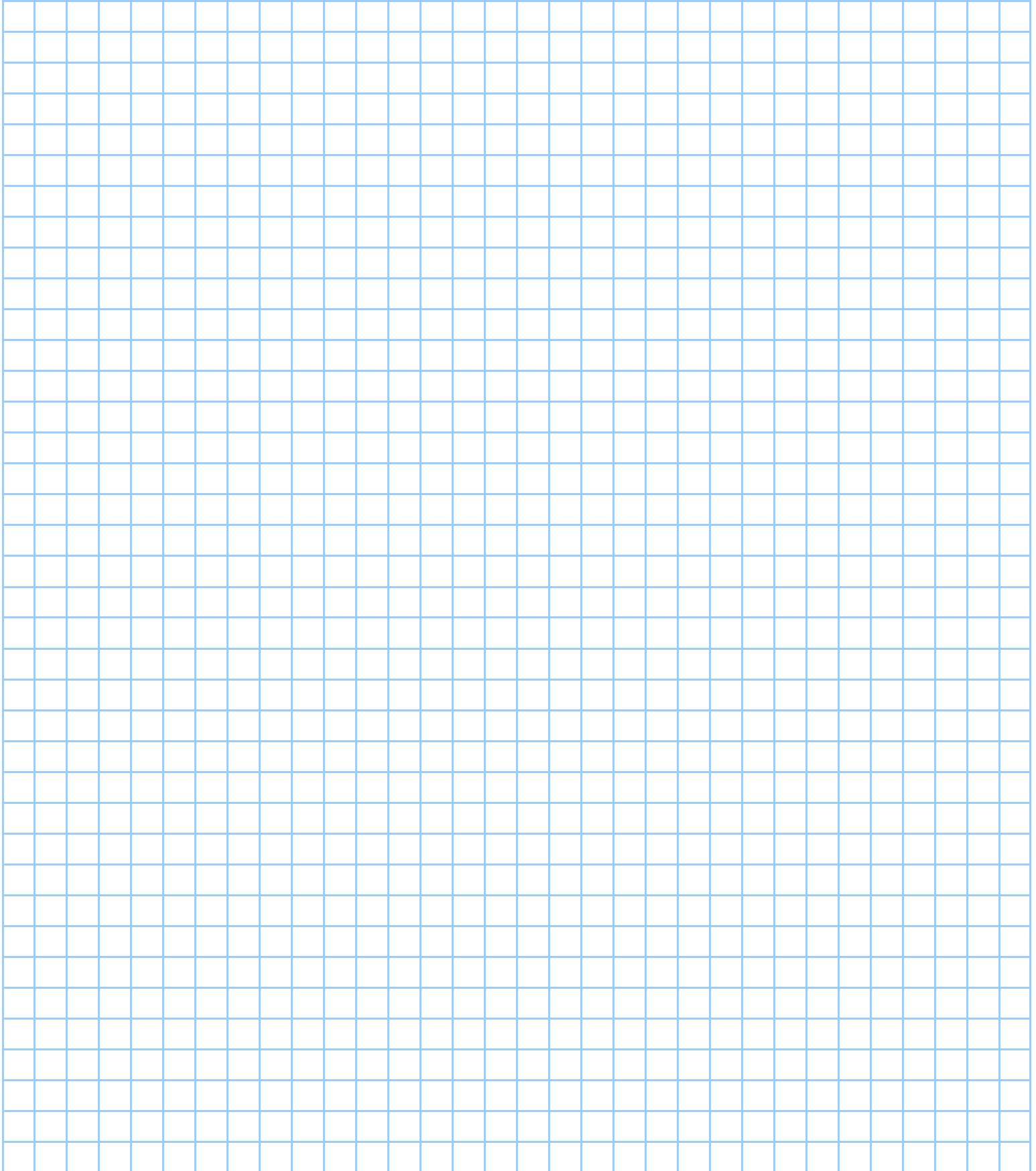

Are You Prepared?

Are *You* Prepared For An Emergency?

If an explosion resulted in a major fire in your area right now, while you are reading this sentence, would you be ready? The history of Vermont, especially in the past 10 years, dramatically illustrates Vermonters' vulnerability to the effects of hazards, both natural and man-made (including the emerging threat of terrorism). These dangers result in a range of problems that threaten life and property. There are, however, some steps that *you* can take to prepare yourself and your family for a disaster. With planning and preparation you and your family will be better able to cope with the difficulties that arise during an emergency.



VERMONT DIVISION OF EMERGENCY MANAGEMENT AND HOMELAND SECURITY

45 State Drive
Waterbury, VT 05671-1300

1-800-347-0488 (Voice)

<http://dps.vermont.gov>



**Contact DEMHS
for additional workbooks**